





7 SERIES: 7.2 K

<http://tiny.cc/7seriesEN>

 MAX LIFTING CAPACITY 1380 kg	 ENGINE POWER 25 hp	 SPEED 9 km/h	 FLOW RATE 40 l/min	 LIFT HEIGHT 2,9 m
--	--	--	--	---



Model	7.2 K
Engine	Kubota D1305 - 3 cylinder - 1261 cc.
Emission Standard	Stage V and Tier 4 Final
Power (Iso Gross) / Torque	25 HP / 85 Nm @ 1700 rpm
Fuel	Diesel
Transmission	Hydrostatic
Drive speed (max.) ⁽¹⁾	9 km/h (5.6 mph)
Aux. hydraulics oil flow	40 l/min (10.5 GPM)
Max. lifting height	2,90 m (114 in)
Tipping load, max. ⁽²⁾	1725 kg (3803 lbs)
Lifting capacity straight, max. ⁽³⁾	1380 kg (3042 lbs)
Breakout force / 50 cm	1700 kg (3748 lbs)
Pushing force (c)	1690 kgf (1690 kp)
Average ground pressure (w/standard tires)	1099 kg/m ² (225 lbs/sqft)
Turning radius: inside/outside	825/2090 mm (32.5/82.3 in)
Standard tires (Tractor profile)	23X10.50-12 ET-25
Weight	1590 kg (3510 lbs)
Product Code	C962025

⁽¹⁾ Maximum speed that can be achieved with the largest diameter tires available, on a flat surface and machine without attachments.

⁽²⁾ Tipping limit, when the machine is straight, with rear weights and boom lifted just off the ground. Weight of attachment included.

⁽³⁾ Maximum load that can be lifted just off the ground when the machine is straight and with rear weights. Weight of attachment is included.

Note: Refer to the Operator's manual for the comprehensive load diagram.

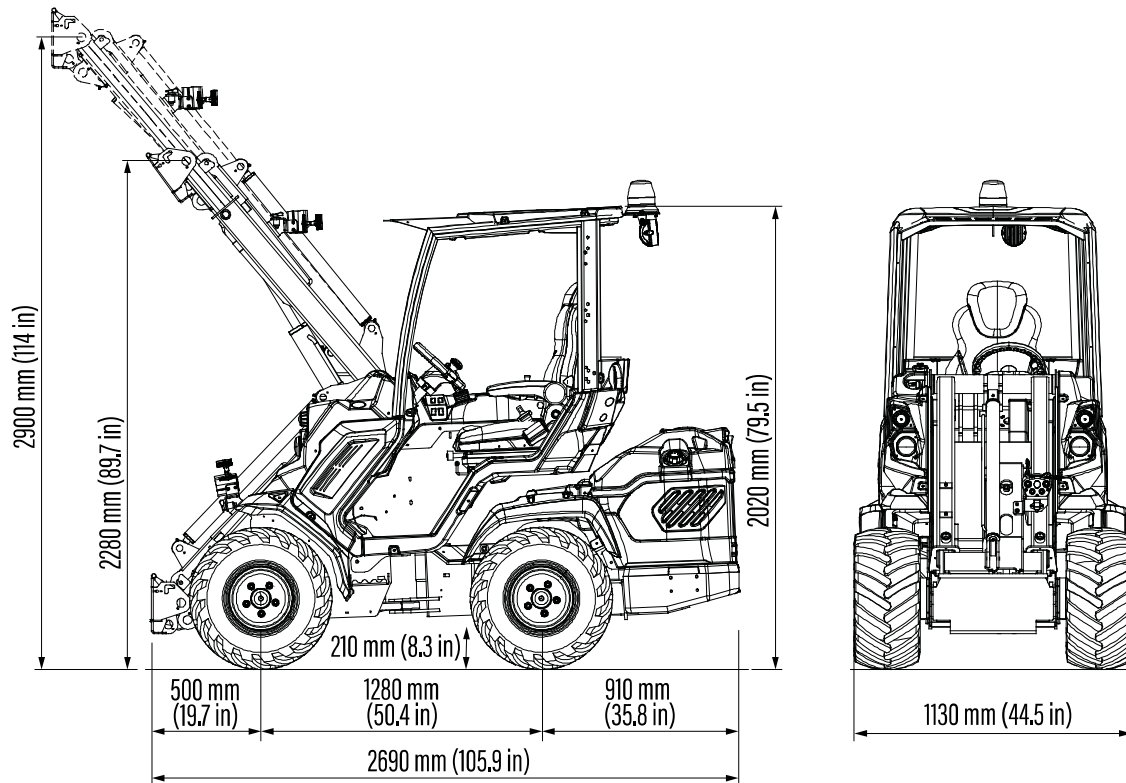

Tires size	Height	Width
23X8.50-12	2020 mm (79.5 in)	1070 mm (42.2 in)
23X10.50-12 ET-25	2020 mm (79.5 in)	1130 mm (44.5 in)
26X12.00-12 ET-50	2040 mm (80.3 in)	1280 mm (50.4 in)
27X8.50-15	2080 mm (81.9 in)	1070 mm (42.1 in)
27X10.50-15	2080 mm (81.9 in)	1150 mm (45.3 in)

FEATURES

- Kubota D1305 (25 HP), big block, 3 cylinder, diesel engine, water cooled, electric start, glow plug
- Stage V and Tier 4 Final compliant engine
- Unbreakable Body Panels
- DBS (Dynamic Block System)
- Self-locking multi-disk parking brake
- Integrated rear weights
- Hydraulic oil cooler
- Hydraulic multiconnector
- Hydraulically pilot operated variable displacement drive pump
- 2 front working light
- Self-levelling double-H telescopic boom
- 4WD hydrostatic Direct Drive motors, proportional servo control
- 4-functions joystick
- ROPS-FOPS Level I
- LCD graphic display with programmed service
- Ergonomic heated full adjustable suspension seat with armrests and seat belt
- Radial piston high efficiency and heavy duty wheel motors